

1 DESCRIPTION

The ASI1431 is an analog I/O module intended for use in the ASI2416 Modular CobraNet™ Interface. It contains eight inputs and outputs that operate at a 48kHz sample rate.

Up to four ASI1431 modules may be used in one ASI2416. AudioScience's CobraNet implementation, based on the CobraNet chip used, allows for up to 16 inputs and outputs, out of a possible 32, to be used at any given time.

A unique feature of the ASI1431 is its interchangeable I/O connector. A choice of 50pin Centronics (ASI1491), StudioHub+™ (ASI1492) or Terminal Block (ASI1493) allows the module to adapt to a wide variety of interconnection schemes with minimal custom wiring.

2 FEATURES

- Eight inputs and outputs
- 24bit analog-to-digital and digital-to-analog converters: 105dB SNR and 0.0015% THD+N
- -10 to +24dBu software controlled output and input level
- Interchangeable Module Connectors with choice of Terminal Block, StudioHub+™ RJ-45 or 50pin Centronics connector (compatible with AudioScience sound cards)
- Up to four modules can be used in one ASI2416

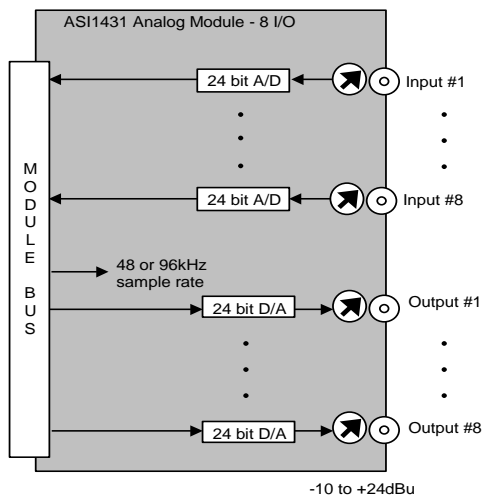

ASI1431

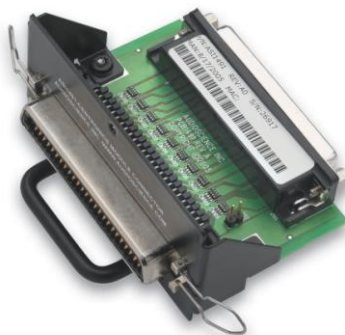

ASI1491
50 pin Centronics



ASI1492
StudioHub

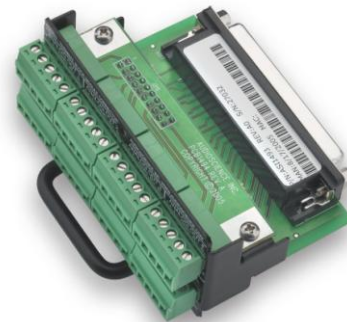

ASI1493
Terminal Block

3 SPECIFICATIONS

ANALOG INPUT/OUTPUT

Type	Balanced
Input Level	-10 to +24dBu in 1dBu steps
Input Impedance	10K ohms
A/D converter	24bit Over sampling
Output Level	-10 to +24dBu in 1dBu steps
D/A converter	24bit Over sampling
Load Impedance	600ohms or greater
S/N Ratio[1]	>105dB (record or play)
THD+N[2]	<0.0015% (record or play)
Sample Rates	48, 64, 88.2, 96 and 192kHz
Frequency Response	20Hz to 20kHz +0.1/-0.30dB

SAMPLE RATE CLOCK

Internal	48kHz (CobraNet)
----------	------------------

CONNECTOR MODULES

ASI1491	50 pin Centronics
ASI1492	StudioHub compatible RJ-45 jacks.
ASI1493	5 position 3.81mm pluggable terminal block (8 per module)

GENERAL

Bus	AudioScience ASI2400 series module bus
Dimensions	(Without Module Connector) 5.5" x 3.25" x 0.6" (140mm x 83mm x 15mm)
Weight	8 oz (227g) max
Operating Temperature	0C to 70C
Power Requirements	+5V @ 500mA

[2] - THD+N measured using a +20dBu 1kHz sine wave sampled at 48kHz, 20-20kHz b/w and A weighting filter
 [1] - S/N Ratio is the difference between a 1kHz +20dBu sine wave and digital zero using an A weighting filter and 20-20kHz b/w



4 REVISIONS

Date	Description
27 June 2009	Elaborated first page, second paragraph.
	Updated format, including adding a REVISIONS section.
03 December 2009	Section 3 - Adjust frequency response to +0.1/-0.3dB
06 April 2010	Section 5.3: Added Rev numbers

5 MODULE CONNECTORS

5.1 ASI1491 - 50pin Centronics

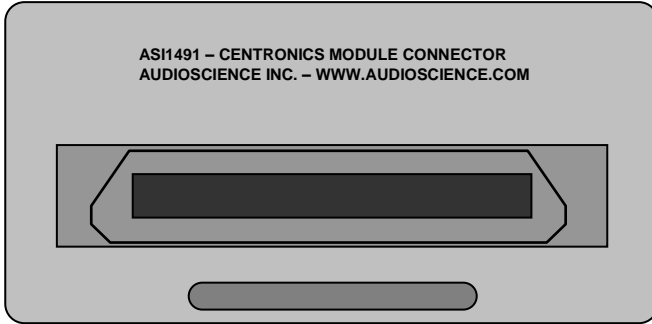

The ASI1491 Module Connector provides a 50pin Centronics connector (also referred to as a 50pin SCSI connector). AudioScience's CBL1044 XLR breakout cable can be used with this connector.

The table to the right shows the pinouts when used with the ASI1431 Analog Module.

50pin Centronics Connections			
Signal	Pin #	Pin #	Signal
Input 1 -	1	26	Input 1 +
Input 2 -	2	27	Input 2 +
Input 3 -	3	28	Input 3 +
Input 4 -	4	29	Input 4 +
Input 5 -	5	30	Input 3 +
Input 6 -	6	31	Input 6 +
Input 7 -	7	32	Input 7 +
Input 8 -	8	33	Input 8 +
Output 8 -	9	34	Output 8 +
Output 7 -	10	35	Output 7 +
Output 6 -	11	36	Output 6 +
Output 5 -	12	37	Output 5 +
Output 4 -	13	38	Output 4 +
Output 3 -	14	39	Output 3 +
Output 2 -	15	40	Output 2 +
Output 1 -	16	41	Output 1 +
	17	42	
	18	43	
	19	44	
	20	45	
	21	46	
	22	47	
	23	48	
	24	49	
GND	25	50	GND

5.1.1 CBL1044 – 8 Analog XLR In/Out Cable



CBL1044, purchased separately, can be used with the ASI1491 50pin Centronics connector and the ASI1431 analog module. It is a 50pin to 8 in/8 out XLR, balanced analog cable.

5.2 ASI1492 StudioHub (RJ45)

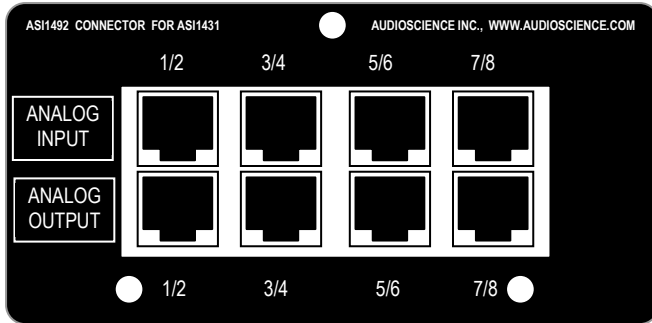

StudioHub (RJ45) Connections		
Pin	Function	Color Code
Shield	Shield	
1	Channel 1/3/5/7 +	White/Orange
2	Channel 1/3/5/7-	Orange/White
3	Channel 2/4/6/8 +	White/Green
4	Ground	Blue/White
5		
6	Channel 2/4/6/8 -	Green/White
7		
8		

The ASI1492 StudioHub Module Connector provides pairs of inputs and outputs on an RJ-45 type jack compatible with the Radio Systems StudioHub standard. This allows the balanced analog signal to be transmitted using shielded twisted pair (STP) cable.

The RJ45 connections are shown in the table to the right.

For more information on the StudioHub standard, see www.studiohub.com.

5.3 ASI1493 Terminal Block

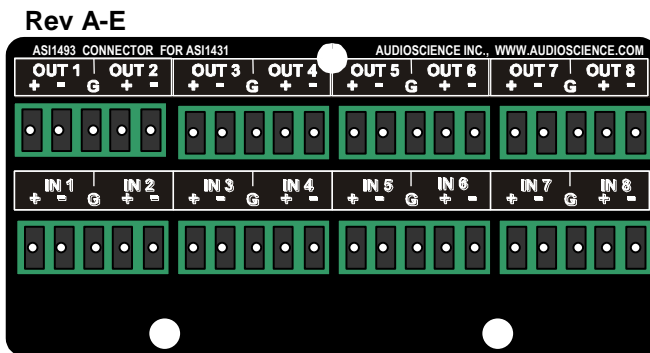

The ASI1493 Terminal Block Connector provides 3.81mm pluggable terminal blocks.

Connections for the ASI1431 Analog Module are shown in the diagram to the left.

<end>