



NOTE 15

ASI6585/Axia Node Demonstration Steps

Introduction

This document provides setup information for a demonstration ASI6585/Axia Livewire node installation on a Windows PC for testing and experimentation. Typical production installations may be more complicated than this. For further information on the ASI6585, please refer to the datasheet found under Products | Network Products | ASI6585 | ASI6585 Datasheet.

Note: Record the ASI6585 serial number (found on a white sticker on the back of the adapter), and MAC address (found on the reverse side of the ASI6585 faceplate) in a safe place. If you change the default IP address of the ASI6585, record that in a safe place as well.

CAUTION: Livewire devices should NOT be part of your office network. They must be on a separate network. See <http://www.axiaaudio.com/> for further details.

Basic Network Setup

The setup illustrated to the right can be used for simple Livewire experiments in a lab environment. Note that this diagram assumes that your office network is 192.168.0.X. All IP addresses are for illustration purposes only. Your specific addresses may be different.

Sources and Destinations

Axia devices deal in 'Sources' and 'Destinations'. This terminology is used because the traditional terms of "inputs" and "outputs" really mean something else. Think of "sources" as audio streams that are being delivered to the network. Think of the "destinations" as the device to which one of these streams is being delivered. **For example, the audio streams played through an ASI6585 (or some other Axia node) are the 'sources' to the Axia Livewire network. Audio streams coming into the ASI6585 (or some other Axia node) for recording or play-through are the 'destinations.'**

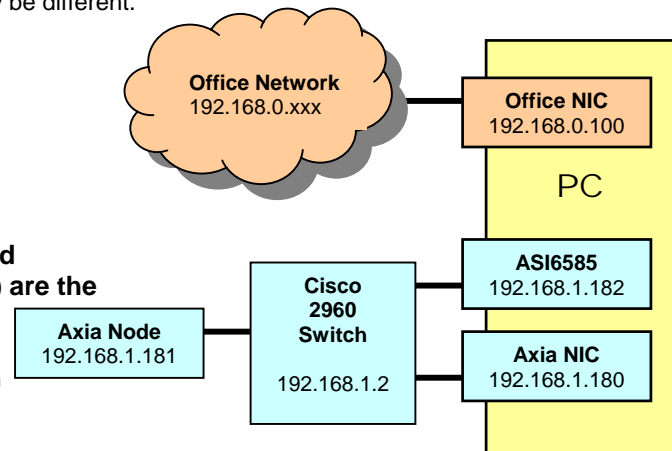

Cisco Switch

Axia has tested and recommends Cisco switches for use in Axia networks. Please see <http://www.axiaaudio.com/switches/default.htm> for more information. Any Ethernet switch used with an Axia Livewire network must be configured to properly handle multicast (IGMP or Internet Group Multicast Protocol). A Cisco switch "out of the box" is not configured. A good document that describes the recommended Cisco 2960 switch configuration for Livewire is found here:

http://www.axiaaudio.com/manuals/files/Axia_Cisco2960_config.pdf

Setup for Testing ASI6585/Axia Node Configuration

This assumes you start with one Network Interface Card (NIC) in the machine connected to your office network.

1. **Install the ASI6585.** Shut down the PC if it is running and install the ASI6585 in your PC. Turn the PC on and cancel out of the Windows Found New Hardware Wizard when it shows up. AudioScience driver version 3.08.00 or newer must be downloaded and installed. Go to www.audioscience.com and under Download, click Windows Drivers. Scroll down and select the correct driver for your application – WAVE, WDM or Combo (for help, look at the top of the page under 'Information about our drivers'). A reboot is required after installing the driver.

2. **Give office network a name.** Go to Start | Control Panel | Network Connections. You should see the 'Local Area Connection' for your office network. Right click on the Local Area Connection, select "Rename," and give it a meaningful name to associate it with your office network (for example, Office Network) if it isn't already.
3. **Install a second NIC.** Shut down the machine and install a second Network Interface Card (NIC). If necessary, install the appropriate driver. This NIC will be used strictly for the Axia network.
4. **Give Axia network a name.** Go to Start | Control Panel | Network Connections. You should now see a second Local Area Connection. Right click on the new Local Area Connection, select "Rename," and give it a meaningful name for your Axia network (for example, Axia Network)
5. **Set IP address of Axia NIC.** Right click on the Axia connection, then click on Properties.

- a. In 'This connection uses the following items', click once on 'Internet Protocol (TCP/IP)', typically found at the bottom of the list, then click 'Properties.' You'll see the 'Internet Protocol (TCP/IP) Properties' dialog box, as shown on the right.
- b. Click the radio button for "Use the following IP address" and enter the following information:
 - i. 192.168.1.180 for the IP address
 - ii. 255.255.255.0 for the netmask
 - iii. Leave the Default Gateway blank
 - iv. Leave DNS server addresses blank
- c. Click OK and the Internet Protocol (TCP/IP) Properties dialog box closes. Click "Close" on the Office network Properties dialog box.

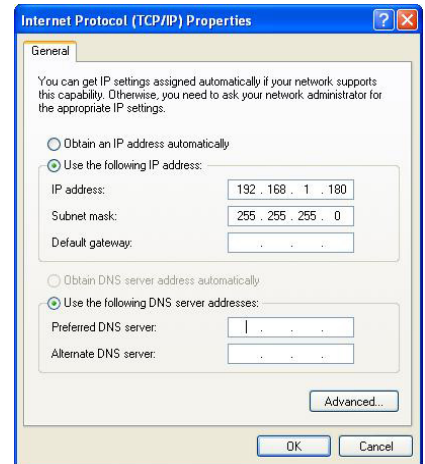

6. **Connect ASI6585 to Cisco switch.** Using Cat 5 or Cat5e cables (Cat5e is recommended), connect your ASI6585 and your Axia node to your Cisco switch. Your original NIC card should still be attached to your office network. Your configuration should look similar to the test setup diagram at the beginning of this document.
7. **View the ASI6585 via web browser.** The PC can now communicate with the ASI6585. To test this:
 - a. Open a web browser (Internet Explorer, Firefox, etc.). You may see a message like 'no connection to the Internet is available.' In IE, click on 'Work Offline.'
 - b. In the URL bar, type in '192.168.1.182' and hit Enter.
 - i. The web interface for the ASI6585 will come up.
 1. When first clicking on a tab, you'll be prompted for a username and password. The username is 'user' and the password is " " (i.e.: there is no password).
 2. Click on the Sources tab (see below). Rename these to something more meaningful if you want. These sources are what you can select from in another nodes' Destinations.
 - a. **CAUTION:** The channel numbers for the Sources must be unique to each Axia node. Make sure the Source channel numbers defined for the ASI6585 are different than the Source channel numbers defined for all other Axia nodes on your Axia network.

Source				Streams	Inputs
#	Name:	Channel:	Shareable:	Mode:	Gain [dB]:
1	SRC 1	18201	Yes	Fast Stereo	0.0
2	SRC 2	18202	Yes	Fast Stereo	0.0
3	SRC 3	18203	Yes	Fast Stereo	0.0
4	SRC 4	18204	Yes	Fast Stereo	0.0
5	SRC 5	18205	Yes	Fast Stereo	0.0
6	SRC 6	18206	Yes	Fast Stereo	0.0
7	SRC 7	18207	Yes	Fast Stereo	0.0
8	SRC 8	18208	Yes	Fast Stereo	0.0

Apply

8. **View the Axia node via web browser.** Open another browser window (or tab) and enter the IP address for your Axia node.
 - a. The web interface for the Axia node will come up (in the example illustrated here, an Axia Analog node).
 - i. When first clicking on a tab, you'll be prompted for a username and password. The username is 'user' and the password is " " (i.e.: there is no password).
 - ii. Click on the Destinations tab (see below). Rename these to something more meaningful if you want.



- b. Click on the dropdown box to see a list of all available Sources. Select an ASI6585 Source for each Destination channel of the Axia node and click "Apply."
9. **Play audio files using ASiControl.** Open ASiControl (or ASiMixer, which is downloaded separately from our Applications page and used with our WAVE driver) and for each 8 Players of the ASI6585, browse and select audio files to play. You may want to select the Repeat option.
10. **View Axia node output meters.** Press the Select button on the Axia node until you see the output meters. You should see all 8 pairs of meters moving on the Axia node at this point.

<end>