

1 DESCRIPTION

The ASI1462 and ASI1464 are analog microphone/line input modules intended for use in the Hono AVB/CobraNet Custom network interfaces. They contain eight microphone pre-amplifiers that operate at a 48kHz sample rate.

The ASI1462 has fully balanced inputs with software selectable +48V phantom power. The ASI1464 is intended for aviation simulation applications and has unbalanced inputs with software selectable +12V phantom power.

Up to four ASI1462/4 modules may be used in one Hono Custom giving a maximum of 32 pre-amp inputs^[5], with up to 16 of those inputs able to be streamed over the CobraNet network at one time. AVB may use all 32 possible channels.

Powerful floating point DSP processing in the Hono Custom provides each microphone pre-amp with a 5-band parametric equalizer and compressor/limiter. A unique feature of the ASI1462/4 is its interchangeable I/O connector. A choice of 50pin Centronics (ASI1491), StudioHub+™ (ASI1492), Terminal Block (ASI1493), or 8 1/4" TRS inputs (ASI1494) allows the module to adapt to a variety of interconnection schemes with minimal custom wiring.

2 FEATURES

- Eight microphone pre-amplifiers/line inputs
- ASI1462: Low noise balanced microphone input with selectable 48V phantom supply
- ASI1464: Low noise un-balanced microphone input with selectable 12V phantom supply
- -60 to +26dBu software controlled input level
- -98dB THD+N, 105dB DNR, -120dBu EIN
- Compressor/Limiter
- 5 band parametric equalizer
- Interchangeable Module Connectors with choice of 50pin Centronics connector, Terminal Block, or 8 1/4" TRS inputs
- Up to four modules can be used in one Hono Custom

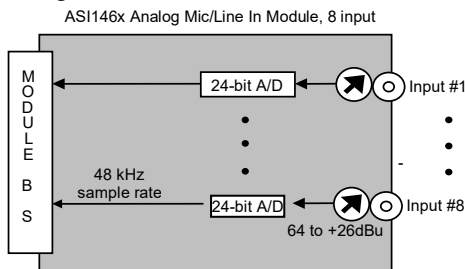

ASI1491
50 pin Centronics



ASI1492
StudioHub



ASI1493
Terminal Block

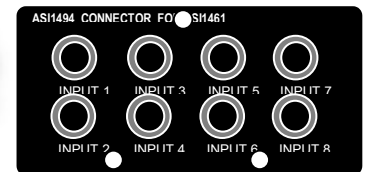

ASI1494
1/4" TRS

3 SPECIFICATIONS

MICROPHONE INPUT

Type	Balanced
Input Level	-60 to +26dBu in 1dB increments
Input Impedance	10K ohms
Phantom Power ^[4]	ASI1464: Unbalanced, +12V @ 5mA max per input, software selectable on each input; on and off
	ASI1462: Balanced +48V @ 10mA max per input, software selectable on each input; on and off
EIN ^[3]	-120dBu
Dynamic Range ^[1]	>105dB
THD+N ^[2]	< -98dB
A/D converter	24bit Over sampling
Sample Rates	48 kHz
Frequency Response	20Hz to 20kHz +/-0.25dB

SIGNAL PROCESSING

Compressor/Limiter ^[5]	Attack, Decay, Input Threshold, Makeup gain.
Equalizer ^[5]	5 band, parametric

SAMPLE RATE CLOCK

Internal	48kHz
----------	-------

CONNECTOR MODULES

ASI1491	50 pin Centronics
ASI1492	StudioHub compatible RJ-45 jacks
ASI1493	5 position 3.81mm pluggable terminal block (8 per module)
ASI1494	8 ¼" TRS inputs

GENERAL

Bus	AudioScience Hono Custom series module bus
Dimensions	(Without Module Connector) 5.5" x 3.25" x 0.6" (140mm x 83mm x 15mm)
Weight	8 oz (227g) max
Operating Temperature	0C to 70C
Power Requirements	+5V @ 500mA

NOTES

	[1]	Dynamic Range measured with Input Level set to +26dBu, using a -60dB 1kHz sine wave and A weighting
	[2]	THD+N measured with Input Level set to +21dBu, using a +20dBu 1kHz sine wave sampled at 48kHz, 20-20kHz b/w and A weighting filter
	[3]	With Z _s = 150ohms and Input level set to -10dBu
	[4]	Phantom power is disabled if the input level is higher than -9dBu
	[5]	The Hono Custom only supports 30 channels of simultaneous Compression/Limiting and Eq

4 REVISIONS

Date	Description
3 February 2012	Added ASI1464 un-balanced version, CBL1044 is now CBL1045 (input only)
12 August 2011	Updated Parametric Equalizer section.
25 January 2011	Corrected pinouts on ASI1491 50pin Centronics section. Added CBL1044 section. Added ASI1492 StudioHub section.
07 April 2010	Added Rev numbers to ASI1493 Terminal Block section.
31 March 2010	Preliminary → Released
25 February 2010	Added image of ASI1492 to page 1.
16 February 2010	Initial release.
13 October 2017	Updated to include AVB compatibility
19 November 2024	Updated Phantom power details in Specifications

5 CONTENTS

1	DESCRIPTION	1
2	FEATURES	1
3	SPECIFICATIONS	2
4	REVISIONS	3
5	CONTENTS	4
6	INPUT CIRCUITRY	5
6.1	ASI1462 BALANCED	5
6.2	ASI1464 UNBALANCED.....	5
7	MODULE CONNECTORS	6
7.1	ASI1491 50PIN CENTRONICS	ERROR! BOOKMARK NOT DEFINED.
7.1.1	<i>CBL1045 – 8 Analog XLR In Cable</i>	<i>Error! Bookmark not defined.</i>
7.2	ASI1492 STUDIOHUB (RJ45)	ERROR! BOOKMARK NOT DEFINED.
7.3	ASI1493 TERMINAL BLOCK	ERROR! BOOKMARK NOT DEFINED.
1.1	B1 B2 B3 B4 COM.....	ERROR! BOOKMARK NOT DEFINED.
1.1.1	<i>GPIO OUT</i>	<i>Error! Bookmark not defined.</i>
7.4	ASI1494 8 ¼” TRS	7
8	CONFIGURATION	8
8.1	PHANTOM POWER	8
8.1.1	<i>Input Level</i>	8
8.2	PARAMETRIC EQUALIZER.....	9
8.2.1	<i>Interface</i>	9
8.2.2	<i>Developer</i>	9
8.3	COMPANDER.....	10
8.3.1	<i>Developer</i>	10

6 INPUT CIRCUITRY

6.1 ASI1462 Balanced

The input circuitry of the ASI1462 supports balanced audio. +48V phantom power is individually switchable on each channel under software control. The following diagram shows a simplified schematic of the input circuitry

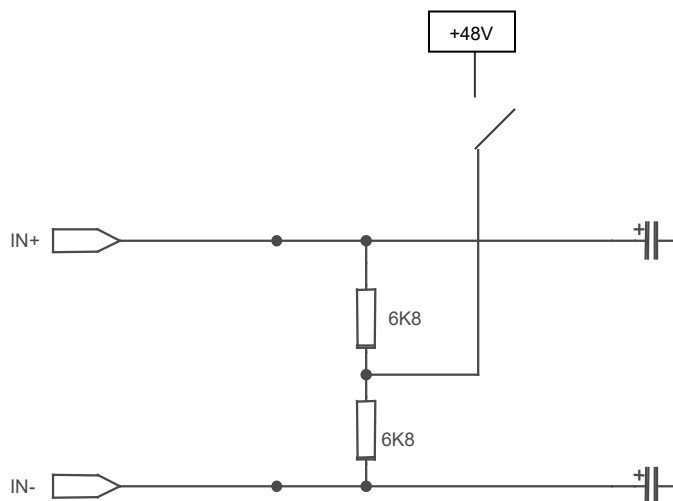

6.2 ASI1464 Unbalanced

The input circuitry of the ASI1464 supports un-balanced audio. +12V phantom power is individually switchable on each channel under software control. The following diagram shows a simplified schematic of the input circuitry

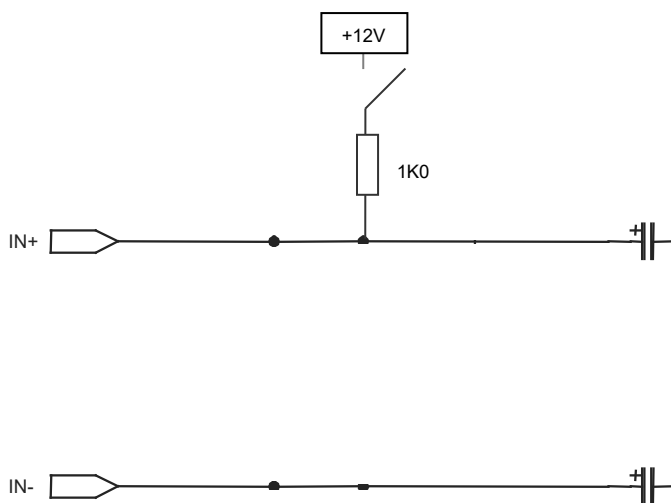

7 MODULE CONNECTORS

7.1 ASI1491 50pin Centronics

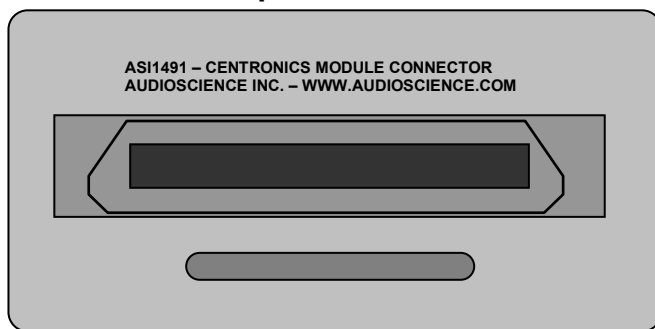

The ASI1491 Module Connector provides a 50pin Centronics connector (also referred to as a 50pin SCSI connector). AudioScience's CBL1146 XLR breakout cable can be used with this connector.

The table on the right shows the pinouts of the connector when used with the ASI1462 mic/line In Module.

50pin Centronics Connector			
Signal	Pin #	Pin #	Signal
Input 1 -	1	26	Input 1 +
Input 2 -	2	27	Input 2 +
Input 3 -	3	28	Input 3 +
Input 4 -	4	29	Input 4 +
Input 5 -	5	30	Input 5 +
Input 6 -	6	31	Input 6 +
Input 7 -	7	32	Input 7 +
Input 8 -	8	33	Input 8 +
	9	34	
	10	35	
	11	36	
	12	37	
	13	38	
	14	39	
	15	40	
	16	41	
	17	42	
	18	43	
	19	44	
	20	45	
	21	46	
	22	47	
	23	48	
	24	49	
GND	25	50	GND

7.1.1 CBL1045 – 8 Analog XLR In Cable



CBL1045, purchased separately, can be used with the ASI1491 50pin Centronics connector and the ASI1462 Mic/line in module. It is a 50pin to 8 in XLR, balanced analog cable.

7.2 ASI1492 StudioHub (RJ45)

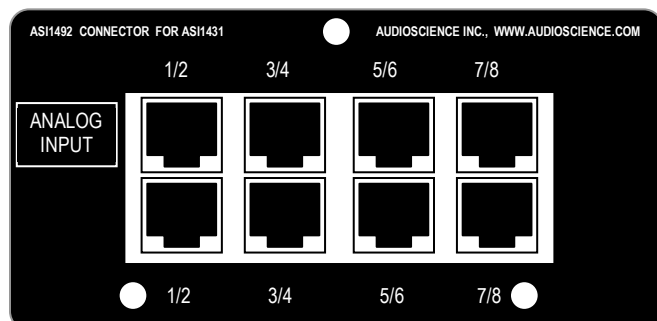

StudioHub (RJ45) Connections		
Pin	Function	Color Code
Shield	Shield	
1	Channel 1/3/5/7 +	White/Orange
2	Channel 1/3/5/7-	Orange/White
3	Channel 2/4/6/8 +	White/Green
4	Ground	Blue/White
5		
6	Channel 2/4/6/8 -	Green/White
7		
8		

The ASI1492 StudioHub Module Connector provides pairs of inputs and outputs on an RJ-45 type jack compatible with the Radio Systems StudioHub standard. This allows the balanced analog signal to be transmitted using shielded twisted pair (STP) cable.

The RJ45 connections are shown in the table to the right.

For more information on the StudioHub standard, see www.studiohub.com.

7.3 ASI1493 Terminal Block

Rev A-E

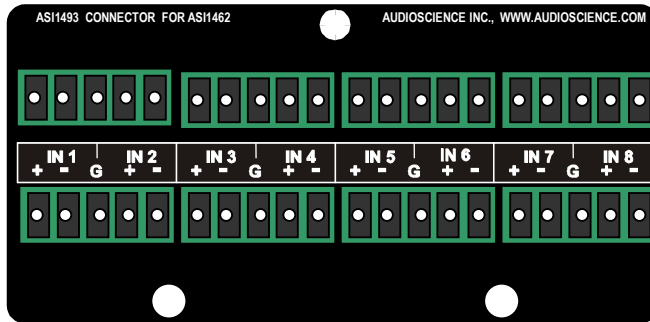

The ASI1493 Terminal Block Connector provides 3.81mm pluggable terminal blocks.

Connections for the ASI1462 Mic/Line In Module are shown in the diagram to the left.

7.4 ASI1494 8 1/4" TRS

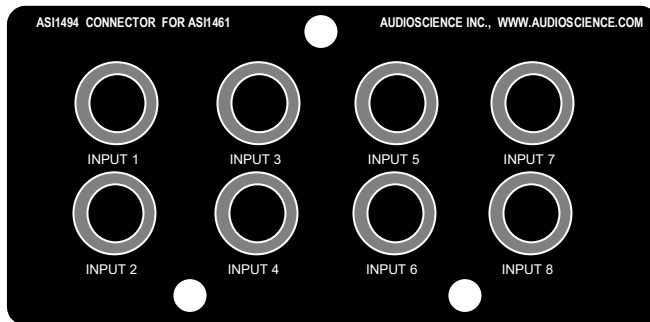

The ASI1494 8 1/4" TRS Connector provides 8 standard 1/4 inch TRS (Tip, Ring, Sleeve) balanced jacks.

Connections for the ASI1461 mic/line In module are shown in the diagram to the left.

8 CONFIGURATION

The ASI1462 module will come pre-installed in an Hono Custom interface. The ASI1462 can be configured over the network using the ASIControl application. For each mic/loin input, the following can be configured

- Phantom power
- Input Level (Sensitivity)
- Parametric Equalizer
- Compressor/Limiter

Here are the controls as viewed in ASIControl's node pane (its right pane):

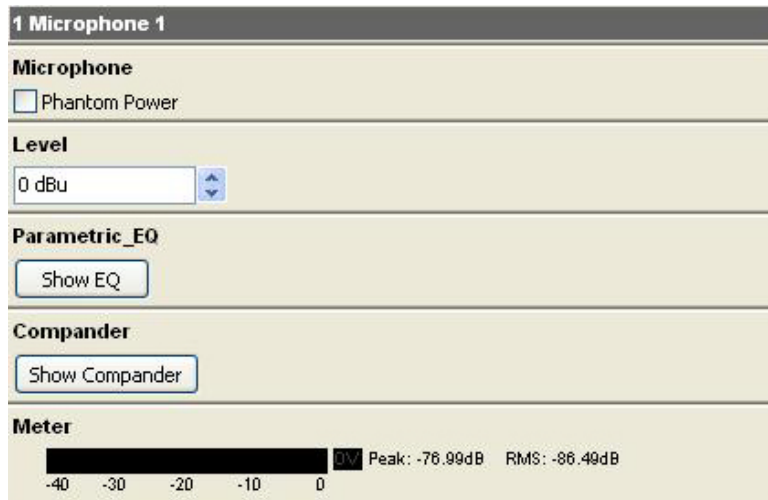

Further information on each control follows.

8.1 Phantom Power



The Phantom power (48v) can be set on and off independently for each channel by checking or unchecking the checkbox.

Note: Phantom power cannot be turned on and will be disabled if the Level is higher than -9dBu.

8.1.1 Input Level



The input level can be set between -60 and +26dBu in 1dB increments by either using the up/down arrows to the right of the Level textbox or by clicking in the Level textbox, typing in a particular number, and then hitting the <Tab> key on the keyboard.

8.2 PARAMETRIC EQUALIZER

The AudioScience parametric equalizer is a 5 band parametric equalizer. It is located on the Line_In and AES/EBU_In nodes and may be used on both the Line In, AES/EBU In, and Microphone signals. Each of the equalizers 5 bands may be individually programmed with filter type (Bypass, Lowshelf, Highshelf, Equalizer, Lowpass, Highpass, Bandpass, and Bandstop), Q (sharpness), and center frequency.

8.2.1 Interface

The Parametric Equalizer is accessed from the ASIControl by clicking on either a Line_In or an AES/EBU_In in the left side of ASIControl then clicking on the “Show EQ” button on the right side of ASIControl.

The Parametric EQ opens, shown below.

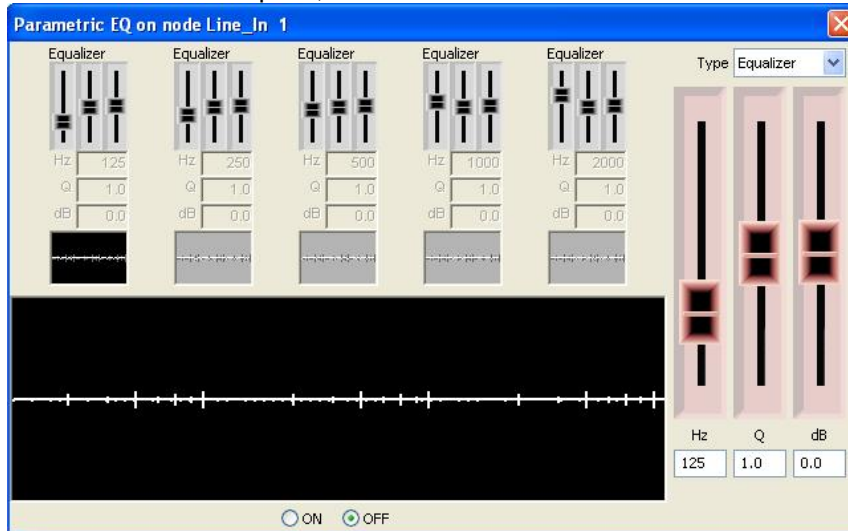

The Parametric EQ as seen in ASIControl

The EQ window contains controls for setting the filter parameters of each of the 5 bands, with a graph showing the combined frequency response of the 5 bands.

Clicking on one of the bands highlights it and changes its small graph display black, as shown on the left band in above. Select the type of graph you want from the Type selection box in the upper right corner, and adjust levels by sliding the large sliders on the right. Click on the next equalizer and change its parameters as needed.

At the bottom of the ASI Parametric EQ pop up, click on the On radio button to activate it.

Each filter band has the following parameters:

Filter Type – The shape of the filter. Supported filter types are:

- Bypass – filter is turned off
- Low Shelf – EQ low shelf
- High Shelf – EQ high shelf
- Equalizer – EQ band (default)
- Low Pass – Standard low pass
- High Pass – Standard high pass
- Band Pass – Standard band pass
- Band Stop – Standard band stop/notch

Filter Hz (Freq) – The center frequency of the filter.

Filter Q – The sharpness of the filter. The higher the Q, the more selective the filter is.

Filter dB (Gain) – The gain of the filter at the center frequency.

8.2.2 Developer

8.2.2.1 Windows APIs

Wave – Use the equalizer mixer control – see “[AudioScience WavX Specification](#)”

HPI – Use the HPI_ParametricEQ_XXXX APIs – see “[AudioScience HPI Specification](#)”

ASX – TBD

8.2.2.2 Linux APIs

HPI – TBD
ASX – TBD
ALSA – TBD

8.3 COMPANDOR

This unit contains a compressor/expander (Companzor), which is used to reduce or expand the dynamic range of the signal it acts on. It is located on the LineIn input and may be used on both the LineIn and Microphone signals.

The companzor is accessed from the ASI Mixer by clicking on the “Companzor” button on the LineIn panel. The following parameters can be set:

Compression Threshold – the input signal level at which the compression starts

Compression Ratio – The ratio of the input signal level to the output signal level

Makeup Gain – additional gain applied the compressed/expanded signal

Attack – Attack time of companzor in milliseconds. Sets the time that the compressor takes to act

Decay – Decay time of companzor in milliseconds. Sets the time for the signal gain to return to normal after compression

Noise Gate –

8.3.1 Developer

8.3.1.1 Windows APIs

Wave – Use the companzor control – see the “AudioScience WavX Specification” (SPCWAVX.PDF)

HPI – Use the HPI_Compandor_XXXX APIs - see the “AudioScience HPI Specification” (SPCHPI.PDF)

Companzor on node Line_In 1

0 dBFS

Output

-100 dBFS

-100 dB 0 dB

On Off

Makeup Gain

0.00dB

Noise Gate

Ratio 1:1

Theshold -60.00 dB

Timing

Attack 100 ms

Decay 5 ms

Companzor

Ratio 1:1

Theshold -20.00 dB

Timing

Attack 5 ms

Decay 100 ms

<end>