

FEATURES

- Twelve mono/stereo streams of PCM playback into four stereo outputs
- Eight mono/stereo streams of PCM record.
- Four stereo balanced analog outputs. Four balanced stereo analog inputs.
- Four transformer coupled AES/EBU digital outputs. Four transformer coupled AES/EBU digital inputs.
- 24bit analog-to-digital and digital-to-analog converters. 105dB SNR and 0.0015% THD+N
- Formats include 8,16 and 32bit PCM
- Sample rates of 32, 44.1, 48, 64, 88.2, 96 and 192kHz
- SSX multi-channel mode
- Up to 4 cards in one system.
- Windows 2000/XP WAVE/WDM and Linux software drivers available.

DESCRIPTION

The ASI5041, ASI5042 and ASI5044 are professional PCI audio adapters designed for use in the broadcast and entertainment markets.

The ASI5041 features four AES/EBU inputs and outputs.

The ASI5042 features four balanced analog stereo inputs and outputs.

The ASI5044 features four balanced analog stereo inputs and outputs and four AES/EBU inputs and outputs.

SSX multi-channel mode allows record, playback and mixing of audio streams of up to 8 channels



ASI5044 – WAVE Driver

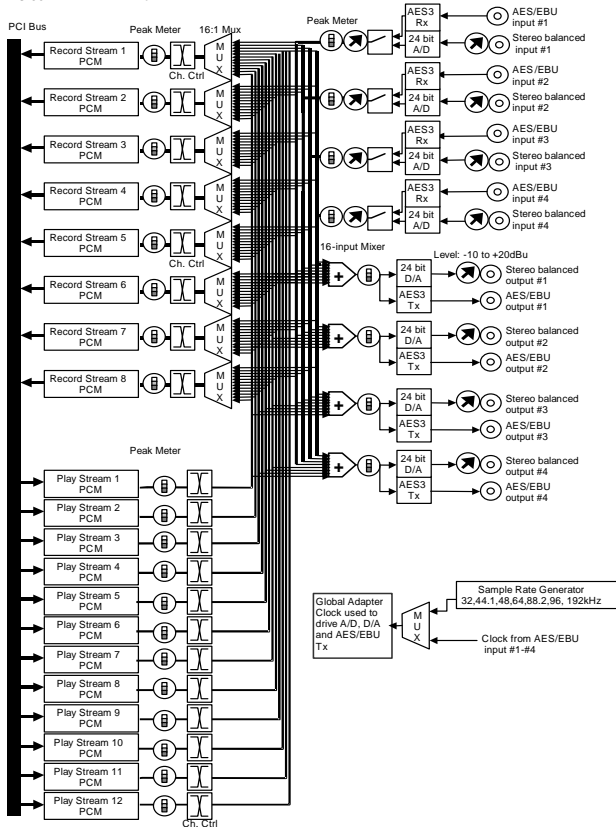

ASI5000 SSX Mode

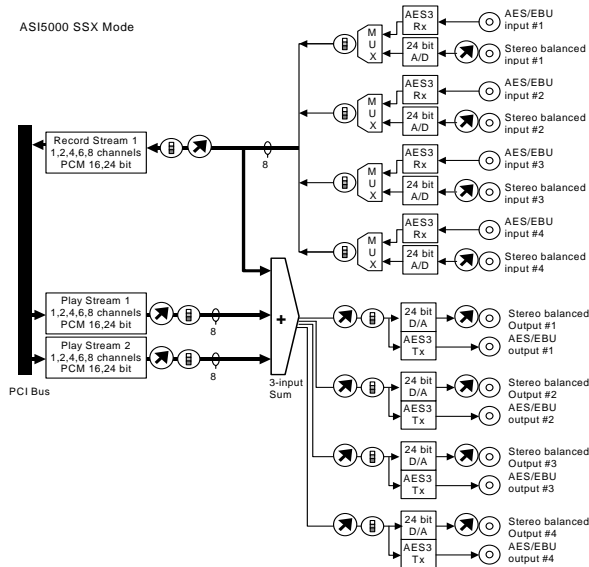

1 SPECIFICATIONS

ANALOG INPUT/OUTPUT

Type	Balanced
Connector	Mini50 (SCSI-II type)
Input Level	-10 to +20dBu in 1dBu steps
Input Impedance	20K ohms
A/D converter	24bit Over sampling
Output Level	-10 to +20dBu in 1dBu steps
D/A converter	24bit Over sampling
Load Impedance	600ohms or greater
S/N Ratio[1]	>105dB (record or play)
THD+N[2]	<0.0015% (record or play)
Sample Rates	32, 44.1, 48, 64, 88.2, 96 and 192kHz
Frequency Response	20Hz to 20kHz +/-0.25dB, 20Hz to 50kHz +0.25/-3dB

DIGITAL INPUT/OUTPUT

Type	AES/EBU (EIAJ CP-340 Type I / IEC-958 Professional)
Connector	Mini26 (SCSI-II type)
Sample Rates	32, 44.1, 48, 64, 88.2, 96 and 192kHz. All inputs must be synchronized.

SAMPLE RATE CLOCK

Internal	32, 44.1, 48, 64, 88.2, 96 and 192kHz
External	Synchronizes to AES/EBU digital input #1-4. NOTE – all AES/EBU inputs must be synchronised to a common clock as the ASI5000 does not have sample rate converters.

SIGNAL PROCESSING

DSP	Texas Instruments TMS320C6205@190MHz
Memory	8MB
Audio Formats	8 bit unsigned PCM 16bit signed PCM 24bit signed PCM 32bit signed PCM

BREAKOUT CABLES

Analog	CBL1004: Mini 50 to Centronics 50 adapter. CBL1044: Centronics 50 to 8 in and 8 out XLR.
Digital	CBL1101: Mini 26 to Centronics 50 adapter. CBL1144: Centronics 50 to 4 in, 4 out XLR

GENERAL

Bus	Universal 32bit PCI (3.3V or 5V signaling)
Dimensions	PCI form factor – 6.5" x 3.9" x 0.6" (165mm x 100mm x 15mm)
Weight	8 oz (227g) max
Operating Temperature	0C to 70C
Power Requirements	+3.3V@500mA, +12V @ 300mA, -12V @ 130mA (NOTE 3.3V must be available from the PCI bus)

[2] - THD+N measured using a +20dBu 1kHz sine wave sampled at 48kHz, 20-20kHz b/w and A weighting filter

[1] - S/N Ratio is the difference between a 1kHz +20dBu sine wave and digital zero using an A weighting filter and 20-20kHz b/w

2 CONNECTORS

Mini 50pin - Analog

LI1-	1	26	LI1+
RI1-	2	27	RI1+
LI2-	3	28	LI2+
RI2-	4	29	RI2+
LI3-	5	30	LI3+
RI3-	6	31	RI3+
LI4-	7	32	LI4+
RI4-	8	33	RI4+
RO4-	9	34	RO4+
LO4-	10	35	LO4+
RO3-	11	36	RO3+
LO3-	12	37	LO3+
RO2-	13	38	RO2+
LO2-	14	39	LO2+
RO1-	15	40	RO1+
LO1-	16	41	LO1+
.	17	42	.
.	18	43	.
.	19	44	.
.	20	45	.
.	21	46	.
.	22	47	.
.	23	48	.
.	24	49	.
GND	25	50	GND

Analog In

Analog Out

Mini 26pin - Digital

AI1-	1	14	AI1+
AI2-	2	15	AI2+
AI3-	3	16	AI3+
AI4-	4	17	AI4+
AO1-	5	18	AO1+
AO2-	6	19	AO2+
AO3-	7	20	AO3+
AO4-	8	21	AO4+
.	9	22	.
.	10	23	.
.	11	24	.
.	12	25	.
GND	13	26	GND

AES/EBU In

AES/EBU Out

3 MIXER MAP

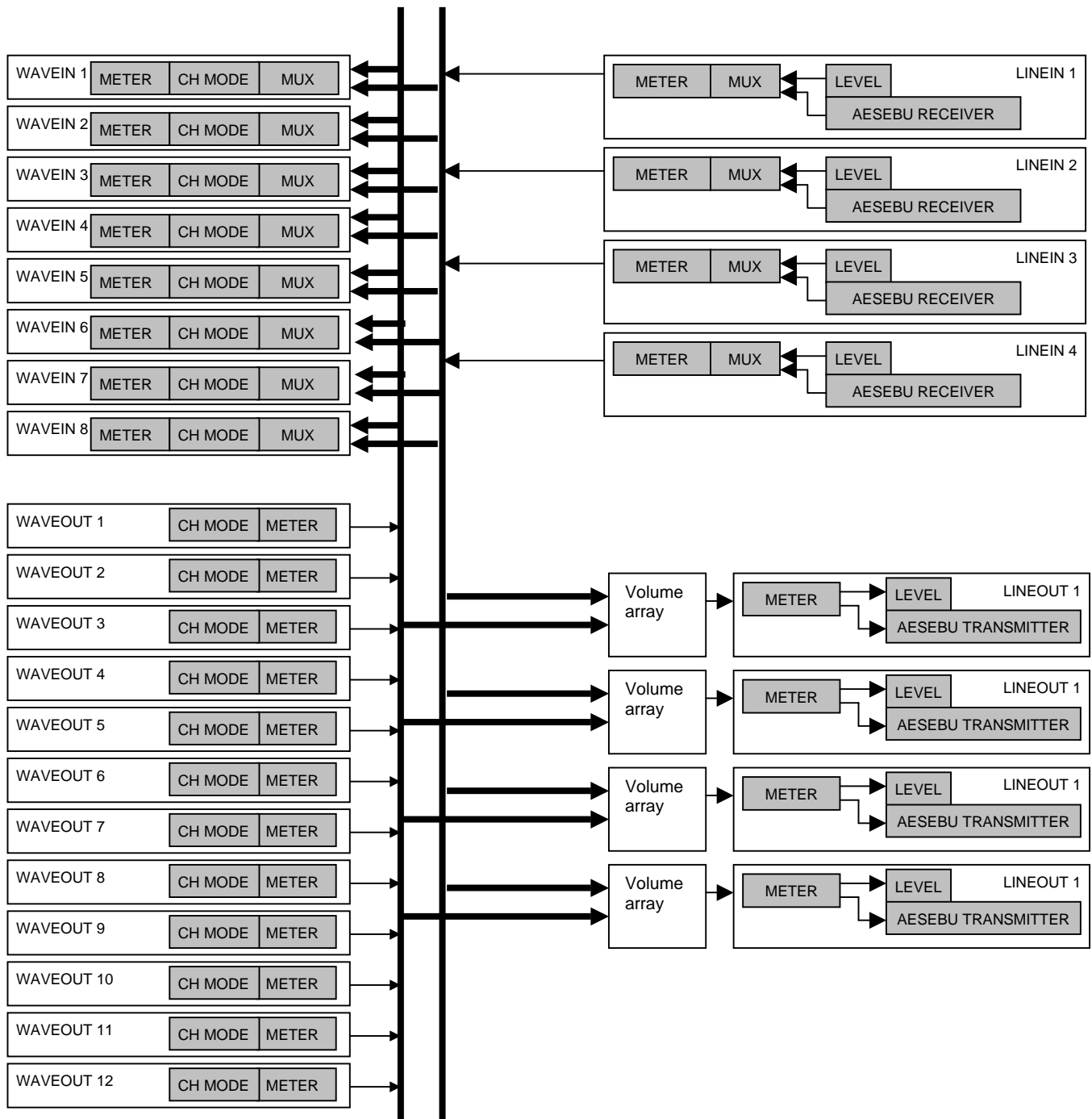

4 AUDIO FORMATS

The ASI504x supports record and play of the following formats:

Format	HPI format	Windows format
8 bit unsigned PCM	HPI_FORMAT_PCM8_UNSIGNED	WAVE_FORMAT_PCM, wBitsPerSample=8
16 bit signed PCM	HPI_FORMAT_PCM16_SIGNED	WAVE_FORMAT_PCM, wBitsPerSample=16
32 bit signed PCM	HPI_FORMAT_PCM32_SIGNED	WAVE_FORMAT_PCM, wBitsPerSample=32
32 bit floating point PCM (+/-1.0)	HPI_FORMAT_PCM32_FLOAT	WAVE_FORMAT_IEEE_FLOAT

5 ADAPTER MODES

The ASI504x supports sample rates up to 192 kHz, but not all rates are available in all modes, or at full sample resolution. The following tables describe the bit resolutions available at various sample rates on an ASI504x. A restart is required after selecting a new mode. The mode setting is saved on the adapter EEPROM.

Adapter Mode 1 (default) – Standard Sample Rate

This mode supports 12 Play streams and 8 Record Streams on ASI5044, ASI5041 and ASI5042. 24 bit sampling is supported up to 48 kHz.

Sample Rate (kHz)	Analog sample resolution	AES/EBU sample resolution
0-48	24	24
48-96	Not supported	Not supported
96-192	Not supported	Not supported

Adapter Mode 2 – High Sample Rate (Analog & Digital)

This mode supports 4 Play streams and 4 Record Streams on the ASI5044 and ASI5042. All sample rates are supported. At sample rates higher than 48 kHz 16 bit sample resolution is used.

Sample Rate (kHz)	Analog sample resolution	AES/EBU sample resolution
0-48	24	24
48-96	16	16
96-192	16	16

Adapter Mode 3 – High Sample Rate (Digital Only)

This mode supports 4 Play streams and 4 Record Streams on the ASI5044 and ASI5041. All sample rates are supported at 24 bits resolution. Analog I/O will not work at rates higher than 48 kHz.

Sample Rate (kHz)	Analog sample resolution	AES/EBU sample resolution
0-48	24	24
48-96	Not supported	24
96-192	Not supported	24

Adapter Mode Multichannel

This mode supports 2 Play streams and 1 Record Stream on the ASI5041/2/4. 24 bit sampling is supported up to 48 kHz. For more information, see the SSX specification - <http://www.audioscience.com/internet/tech/ssx.htm>

Sample Rate (kHz)	Analog sample resolution	AES/EBU sample resolution
0-48	24	24
48-96	Not supported	Not supported
96-192	Not supported	Not supported

6 BALANCED ANALOG I/O

The ASI504X has stereo balanced analog inputs and outputs on a mini 50 pin female connector.

6.1 Analog I/O Level

The analog Level (or Trim) is software programmable independently for the input and output. It can be set from -10 to +20dBu in 1dB increments.

User

Analog levels are adjusted using the Trim/Level controls located on the LineIn and LineOut panels in the ASI Mixer:

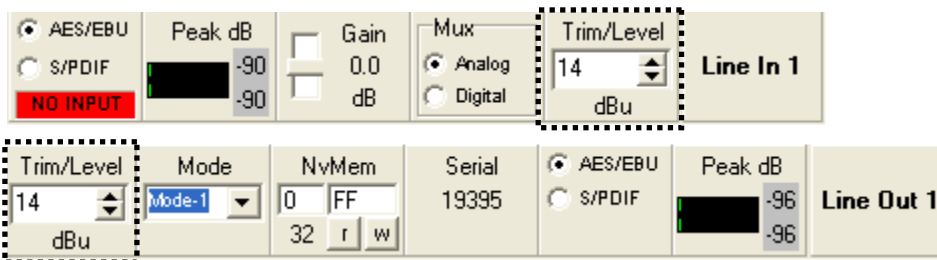

Developer

Windows – Analog levels are controlled using mixerSetControlDetails() on a control of type signed and with the name Level/Trim.

HPI – Analog levels controlled using the HPI_LevelSet() API.

7 AESEBU I/O

The ASI504X has an AES/EBU digital audio input and output on a mini 26 pin female connector. The AES/EBU I/O operates at 32, 44.1, 48, 64, 88.2,96 or 192 kHz. The bitstream contains samples of 24bit precision (depending on the samplerate and adapter mode – see section 5). When a valid AES/EBU source is connected to the ASI504X, the card will automatically generate the sample clock from that source.

7.1 Channel Status and User Data

The ASI Mixer does not setup the Channel Status and User Data in the AES/EBU output. This must be done by the application using the following APIs:

Windows – Use Digital I/O controls – see the “AudioScience WavX Specification” (SPCWAVX.PDF)

HPI – Use HPI_AESEBU_Transmitter_SetChannelStatus() and HPI_AESEBU_Transmitter_SetUserData() APIs

Your application can also read the Channel Status and User Data of the AES/EBU input using the following APIs:

Windows – Use Digital I/O controls – see the “AudioScience WavX Specification” (SPCWAVX.PDF)

HPI – Use HPI_AESEBU_Receiver_GetChannelStatus() and HPI_AESEBU_Receiver_GetUserData() APIs

8 SAMPLE RATE CLOCK

The ASI504X has two methods of generating the sample clock. The default method is to use the on board sample rate generator. The other method is to use the clock derived from one of the AES/EBU inputs.

The Sample Clock Control determines selection between these two clocking options.

User

Sample Clock source is selected using the SampleClk control on the Clock Src node. The options are:

Adapter – the card gets its clock from the internal sample rate generator

AES3 Auto – the card gets its clock from the 1st valid AES/EBU input (starting from #1)

AES3 In 1..4 – the card gets its clock from a specific AES/EBU input (#1 through #4)

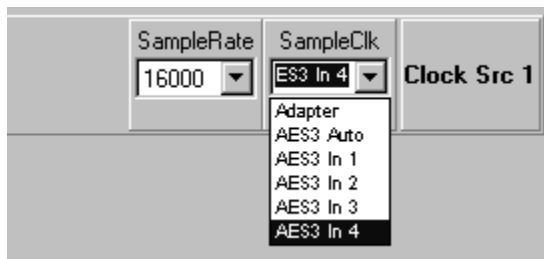

Developer

Windows – The SampleClk control appears as a Windows standard SingleSelect control of type MIXERCONTROL_CONTROLTYPE_SINGLESELECT. Use mixerSetControlDetails() with a details array of type MIXERCONTROLDETAILS_BOOLEAN to set the control value. Use mixerGetControlDetails() with parameter type MIXERCONTROLDETAILS_LISTTEXT and flags set to MIXER_GETCONTROLDETAILSF_LISTTEXT to retrieve the list of strings. Additionally the current setting can be obtained using mixerGetControlDetails () with parameter type MIXERCONTROLDETAILS_BOOLEAN and flags set to MIXER_GETCONTROLDETAILSF_VALUE.

HPI – Use the HPI_SampleClock_SetSource() and HPI_SampleClock_SetSourceIndex() APIs

When using multiple AES/EBU inputs, all AES/EBU inputs should be locked to the same master clock. This is because the ASI504X captures exact digital samples without any sample rate conversion on the input audio data.

[end]