

DESCRIPTION

The ASI6614 is a professional PCI-Express sound card designed for use in radio broadcast automation.

Providing 12 play streams that are mixed to 4 stereo outputs and 2 record streams fed from one stereo input, the ASI6614 features AudioScience's unique "anything to anywhere" mixing and routing.

The ASI6614 provides both balanced analog and AES/EBU inputs and outputs. The maximum analog input and output level is +24dBu.

A choice of uncompressed PCM, MPEG layer 2 and MP3 is available for both recording and playback. All compression is handled by an on-board floating point DSP, allowing the host computer to focus on other tasks.

ASI6614 functionality includes MRX multi-rate mixing technology which allows streams of different sample-rates and formats to be mixed digitally. TSX time scaling allows compression/expansion of any or all playback streams in real time with no change in pitch.

For emerging surround sound applications, SSX mode allows multichannel streams of up to 8 channels to be played and mixed

FEATURES

- 12 mono/stereo streams of playback into 4 stereo outputs
- 2 mono/stereo streams of record from 1 stereo input.
- Formats include PCM, MPEG layer 2 and MP3 with sample rates to 96kHz.
- MRX™ technology supports digital mixing of multiple stream formats and sample rates.
- TSX™ time scaling allows compression/expansion of play streams by up to +/-20% with no pitch shift.
- SSX™ mode for multichannel playback and mixing.
- Balanced stereo analog inputs and outputs with levels to +24dBu.
- 24bit ADC and DAC with 110dB DNR and 0.0015% THD+N
- AES/EBU inputs and outputs with sample rate converters on all inputs.
- Dedicated AES/EBU and Word clock Sync input.
- SoundGuard™ transient voltage suppression on all I/O
- Short length PCI card format (6.6 inches/168mm)
- Up to 4 cards in one system.
- Windows 2000,XP and Linux software drivers available.



ASI6614

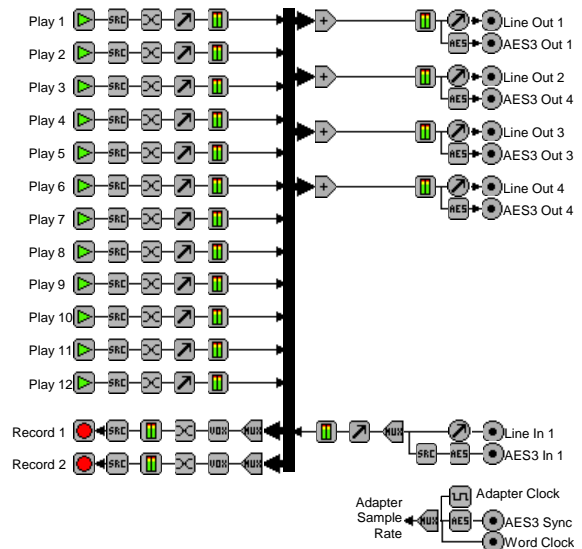

Key:

- | | | | | | | | | | |
|---------------|-------------|--------|-------|-------|---------------|-------|-----------------------|--------------|--------------|
| Record Stream | Play Stream | Volume | Level | Mixer | AES/EBU Tx/Rx | Meter | Sample Rate Converter | Channel Mode | Clock Source |
|---------------|-------------|--------|-------|-------|---------------|-------|-----------------------|--------------|--------------|



1. SPECIFICATIONS

ANALOG INPUT/OUTPUT

Type	Balanced
Connector	Mini50(SCSI-II type)
Input Level	-10 to +24dBu in 0.5dBu steps
Input Impedance	10K ohms
A/D converter	24bit Over sampling
Output Level	-10 to +24dBu in 0.5dBu steps
D/A converter	24bit Over sampling
Load Impedance	600ohms or greater
Dynamic Range[1]	110dB (record or play)
THD+N[1]	0.0015% (record or play)
Frequency Response	20Hz to 20kHz +0/-0.2dB 20Hz to 40kHz +0/-3dB
Inter-channel Phase	<0.1 degrees (record or play)
Inter-channel Crosstalk	>110dB (record or play)

SAMPLE RATE CLOCK

Internal, AES/EBU and Word Clock	32, 44.1, 48, 88.2 and 96kHz
----------------------------------	------------------------------

SIGNAL PROCESSING

DSP	Texas Instruments TMS320C6713@300MHz
Memory	8MB
Audio Formats	8 bit unsigned PCM 16 bit signed PCM 32 bit floating point PCM MPEG-1 Layer 2 MPEG-1 Layer 3(MP3) (MPEG Layer-3 audio coding technology licensed from Fraunhofer IIS and THOMSON multimedia)

BREAKOUT CABLES (NOT INCLUDED)

Analog	CBL1004 : Mini 50 to Centronics 50 adapter. CBL1044: Centronics 50 to 8 in and 8 out XLR.
Digital	CBL1101: Mini 26 to Centronics 50 adapter. CBL1114: Centronics 50 to 1 in, 4 out XLR, 1 BNC in, 1 BNC out (Word Clock).

GENERAL

Bus	X1 PCI-Express.
Dimensions	PCI short-length form factor (6.6 inches/168mm long).
Weight	8 oz (227g) max
Operating Temperature	0C to 70C
Power Requirements	+3V@1.5A, +12V@275mA

[1] – Dynamic Range and THD+N measured using a +20dBu 1kHz sine wave sampled at 48kHz and A weighting filter.

<end>